



## TECHNICAL DATA:

Material: Polypropylene copolymer of first quality, suitable for contact with food according to current regulations.

Colours: White standard. Consult for other colours.

Useful Volume: 16 litres

Volume to the edge: 17 litres

Weight of the bucket: 553 g. approx.

Weight of the lid: 131 g. approx.

Weight of the handle: - metal: 55 g. approx.

- plastic: 3 g. approx.

Total Weight: 742 g. approx.



Decorative surface flat inks: 223 x 822 mm (height x perimeter)

Design surface photographic finish: 230 x 845 mm (height x perimeter)

## MEASUREMENTS:

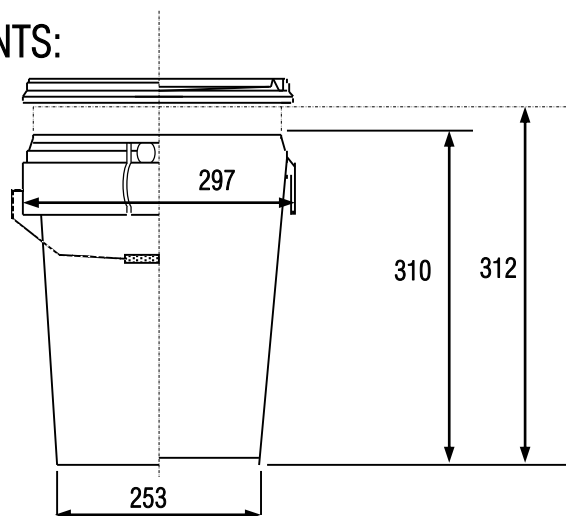

Measurements in millimetres

## GROUPING OF TRANSPORT:

Buckets: 360 buckets per pallet  
Pallet dimensions: 1200 x 900 x 1895 (see drawing)

Lids: 90 lids per bag, this serves as a packaging of transportation

Bag dimension:  $\varnothing$  298 x 870

